

D = max akseli

\* = hitsattu napa

Z = hammasluku

Materiaali SIS 1650

Tilausnumero esim:

06B119 (Iso nr hammasluku)

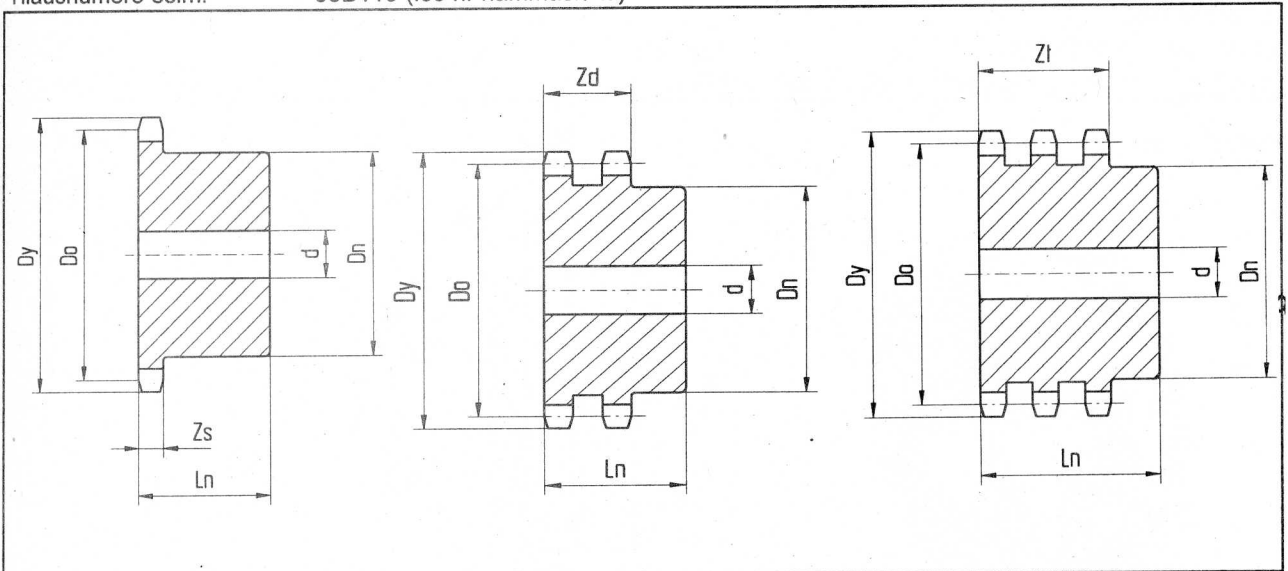

**Ketjulle Iso-nr 28B jako 1 2/4" x 1 1/4" yksirivinen, kaksirivinen ja kolmirivinen**  
44,45 mm

Z	Do mm	Dy mm	28B1 Zs 29,4 mm				28B2 Zd 88,4 mm				28B3 Zt 148,0 mm					
			d mm	Dn mm	Ln mm	Paino kg	d mm	Dn mm	Ln mm	Paino kg	d mm	Dn mm	Ln mm	Paino kg		
8	116,15	132,0	25	74	70	2,2										
9	129,96	148,4	25	88	70	2,9										
10	143,85	162,3	25	100	70	3,8										
11	157,77	176,3	25	112	70	4,8	25	112	120	7,0		30	112	180	21,0	
12	171,74	189,5	25	125	70	5,9										
13	185,74	204,2	25	130*	70	7,7	25	130*	120	9,8		30	130*	180	30,0	
15	213,79	232,3	25	145*	70	11,0	25	145*	120	14,0		30	145*	180	36,0	
17	241,91	260,0	30	160*	75	13,0	30	160*	120	17,0		30	160*	180	48,0	
19	270,06	289,0	30	160*	75	15,0	30	180*	120	21,0		30	180*	180	58,0	
21	298,24	317,0	30	170*	75	18,0	30	180*	120	26,0		30	180*	180	73,0	
23	326,44	345,0	30	170*	75	20,0	30	180*	120	33,0		30	180*	180	88,0	
25	354,65	373,0	30	170*	75	22,0	30	180*	120	39,0		40	180*	180	107,0	
30							30	180*	120	52,0		40	180*	180	148,0	
38	538,27	557,0	30	180*	75	58,0	30	200*	120	75,0		40	200*	180	185,0	
57	806,90	825,0	40	180*	100	81,0										
76	1075,62	1095,0	40	200*	100	127,0										

**Ketjulle Iso-nr 32B jako 2" x 1 1/4" yksirivinen, kaksirivinen ja kolmirivinen**  
50,8 mm

Z	Do mm	Dy mm	32B1 Zs 29,4 mm				32B2 Zd 87,4 mm				32B3 Zt 146,0 mm					
			d mm	Dn mm	Ln mm	Paino kg	d mm	Dn mm	Ln mm	Paino kg	d mm	Dn mm	Ln mm	Paino kg		
8	132,69	153,2	25	82	80	5,0										
9	148,54	169,0	25	88	80	6,1										
10	164,44	185,0	25	104	80	7,2										
11	180,34	200,8	30	120	80	8,5	30	120*	120	17,0		30	120	180	33,0	
12	196,29	216,8	30	133*	80	11,0										
13	212,29	232,8	30	145*	80	13,0	30	145*	120	22,0		30	145*	180	42,0	
15	244,30	264,8	30	160*	80	18,0	30	160*	120	31,0		30	160*	180	53,0	
17	276,40	296,9	30	170*	90	20,0	30	180*	120	38,0		30	180*	180	59,0	
19	308,66	329,1	30	170*	90	24,0	30	200*	120	47,0		30	200*	180	66,0	
21	340,82	361,3	30	180*	90	28,0	30	200*	120	69,0		40	200*	180	86,0	
23	373,07	393,6	30	180*	90	32,0	30	200*	120	73,0		40	200*	180	95,0	
25	405,32	425,8	30	180*	90	38,0	30	200*	120	83,0		40	200*	180	107,0	
38	615,14	635,3	30	180*	90	77,0										
57	922,17	945,0	40	180*	100	140,0										
76	1229,28	1252,0	40	200*	110	270,0										

Maksimi reikä kiilauralla SFS 2636 voidaan yleisesti laskea kertomalla Dn x 06 :lla

Ketjupyörää 28B1-3 ja 32B1-3 ei varastoida

Toimitusaika 2-4 viikkoa.